



# HIGHLIFE® COLLECTION QUICKSTART GUIDE



# Getting Started with Your Hot Spring® Spa

Congratulations on your purchase of a new Highlife® Collection spa! We are excited to welcome you to the Hot Spring family and look forward to becoming an integral part of your daily routine.

This Quick Start Guide is intended to help you set up your hot tub quickly and easily. Use the camera on your smartphone to scan the QR code below or visit [www.hotspring.com](http://www.hotspring.com) to find a digital copy of:

- Your full owner's manual, including the safety and electrical guides
- The FreshWater® Salt System start-up guide and owner's manual



Follow this 9-step process to begin experiencing the rejuvenation and vitality that comes from spending time in a Hot Spring spa.

## Here's What You'll Need

### REQUIRED

- Your chosen water care start-up kit (FreshWater Salt System or other water care system)
- FreshWater 5-Way Test Strips
- FreshWater pH/Alkalinity Up
- FreshWater pH/Alkalinity Down
- Garden hose

### RECOMMENDED

- FreshWater Clean Screen® Pre-Filter and/or On The Go®
- FreshWater Mineral Spa Sanitizer
- FreshWater Concentrated Chlorinating Granules
- FreshWater Vanishing Act® pillow or Vanishing Act XL
- FreshWater Cover Shield



## Follow These 9 Simple Steps

### 1 Safely Connect Your Spa

If you haven't already, hire or consult an electrician to safely connect your spa. Your local dealer can suggest local vendors or help with the installation.

### 2 Test Your Fill Water

- Before filling your spa, take a sample of the water you will use to fill your spa to your local dealer for testing to determine if the water contains high levels of metals, phosphates, and/or calcium.
- Your local dealer can suggest an appropriate water treatment program for your specific fill water.

### 3 Fill Your Spa

- Close the spa's drain, located in the bottom front of the spa.
- Flush out your garden hose before you begin filling your spa.
- Fill your spa through the filter compartment, preferably using the Clean Screen pre-filter hose attachment, until the water level is one inch (2.5 cm) above the highest jet.
- Replace the filter compartment cover.

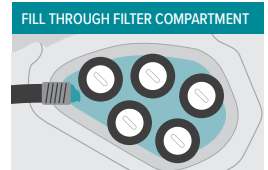
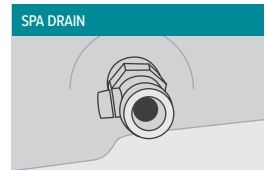

**CAUTION:** Filling the spa through the basin can result in an airlock and difficulty starting the spa.

### 4 Power On Your Spa

- After the spa has been filled with water, turn on the power.
- Open the door of the electrical subpanel and switch on the GFC breakers.
- Close and secure the subpanel door.

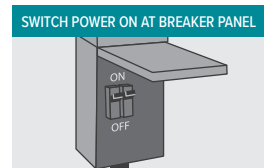

## 5 Set the Water Temperature

- A. Use the control panel to set the temperature to your desired level, which should be at least 95°F (33°C). We recommend temperatures between 100°F (38°C) and 104°F (40°C).
- B. Place the cover on the spa and allow the water to heat up for approximately 24 hours.



## 6 Set Up Your Watercare System

- A. If you purchased a FreshWater® Salt System, open the starter kit and proceed with setup or scan the QR code in this guide for instructions.

**NOTE:** The FreshWater Salt System will not start until a temperature of 95°F has been reached.

- B. Or follow the directions provided by your dealer for your chosen water care system.

## 7 Test the Jets

Check the operation of the jet system and purge any remaining air from the heating system by completing the following steps:

- A. Make sure all diverters are set in the middle.
- B. Use the control panel to turn on all jet pumps, as explained in the “Using the Control Panel” section of this guide.
- C. Confirm each jet is working properly by checking both low and high speed (if applicable). Properly working jets are indicated by strong, non-surging water flow. If jets are surging, turn them off, wait five seconds, and turn them back on.
- D. Cycle through all diverter valves to ensure all systems are flushed with water.
- E. Turn off all jets.

CENTER ALL DIVERTERS



## 8 Balance Your Water

- A. Dip a FreshWater® 5-Way Test Strip into the water for two seconds, remove and shake once, then compare the strip to the scale on the side of the test strip bottle to test the pH, alkalinity, calcium, and chlorine levels.
- B. Adjust the levels as needed to bring your water within the target levels. Refer to your spa's owner's manual or the FreshWater Salt System owner's manual for more detailed information on how to balance your water.
- C. Target levels
  - Total alkalinity (TA) 40–120 ppm
  - pH between 7.2–7.8
  - Calcium hardness
    - 25–75 ppm for salt spas
    - 50–150 ppm for non-salt spas
  - Free chlorine 1–5 ppm

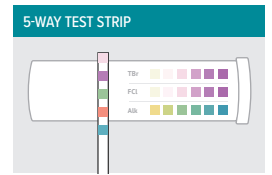

## 9 Sanitize Your Water

- A. Add the recommended amount of sanitizer based on your selected water care system.
- B. Ranges will be dependent on your chosen water care option and/or country. For more specifics on water sanitization, contact your dealer or review the FreshWater Salt System start-up guide, owner's manual, or the instructions included with your water care system.

**Now You're Ready for  
Your First Soak!**

Control Panel instructions on next page →



# Using the Control Panel

Touch anywhere on the screen to turn on the control panel.

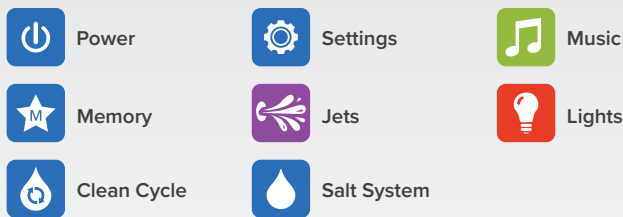

## SETTING THE TEMPERATURE

- Press the temperature icon **102°** shown on the home screen to display the set temperature screen.
- Press the up-arrow icon **▲** to raise the set temperature of the spa. Press and hold to raise the temperature continuously.
- Press the down-arrow icon **▼** to lower the set temperature of the spa. Press and hold to lower the temperature continuously.

## OPERATING THE JETS

- After pressing the Jets button **☙**, press the power button **OFF** to turn all jet pumps off (if they are on) or all jet pumps to high speed (if they are off).
- Press the single jet icon button **☙** to turn the jet pump on low speed.
- Press the double jet icon button **☙☙** to turn the jet pump on high speed.
- Press the off button **⏻** to turn the jet pump off.

## USING THE LIGHTING

- After pressing the Lights button **💡**, press the power button **⏻** to turn all lights on or off. All lights will be blue when turned on.
- Press the left or right arrow **◀ ▶** to decrease or increase the brightness setting for all lights that are currently on.
- Press any of the color boxes **■ ■ ■** to turn that color on in all light zones.
- Press the multicolored box **■ ■ ■** to turn the color wheel on in all light zones. Press the color wheel a second time to stop at the desired color.
- Press the right-facing arrow **➡** to advance to the secondary lights screen for additional lighting options.

For all other functions, including system mode, cleaning mode, tool menu, locking features, sleep mode, filter cycles, and audio, please refer to your owner's manual.

# Maintenance Tips

Protect your investment for years to come with these important tips.

## CARE FOR YOUR SPA SHELL AND COVER

- A soft rag should easily remove most dirt from your spa's shell. Most household chemicals are harmful to the shell, especially Windex or anything with citrus.
- Do not allow any items, including children or pets to sit on the cover.
- Regularly clean and condition your spa cover:
  - After rinsing, a very mild soap solution can be used: one teaspoon of dishwashing liquid with two gallons / 7.5 liters of water.
  - Use water only on the underside of the cover.
  - If necessary, you can scrub the outside of the cover with a soft brush, then rinse well and condition with FreshWater® Cover Shield.  
*NOTE: FreshWater Cover Shield should only be used on vinyl covers. Do not use if your spa has a polyester cover.*

## WARNING! Protect Your Spa Against Sun Damage

- Be aware of reflections from double-paned windows shining on the spa. These reflections can cause severe damage including warped panels, a melted cover core, and potentially even fire.  

- Direct sunlight on an empty spa can cause the shell to blister. This can happen very quickly, especially with darker shell colors. Always keep the spa cover on when not in use.

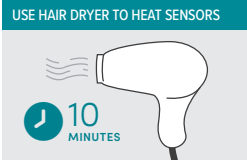
## WARNING! Filling Your Spa With Cold Water

- If the water used to fill your spa is below 50° F (10° C), the spa may go into High Limit Protection Mode and stop functioning. If the issue does occur,
  - Disconnect power to the spa completely.
  - Warm the two sensors on top of the heater and the vinyl tubing (located in the equipment compartment) with a hair dryer for approximately 10 minutes.  

  - Reconnect the power to the spa.
- You may also resolve the issue by blending warm water into your cold fill water to raise the temperature above 50° F (10° C) during the refilling process.

# IMPORTANT SAFETY INSTRUCTIONS

# READ ALL OF THIS INFORMATION BEFORE USING YOUR SPA

## SAFETY INFORMATION

### (READ AND FOLLOW ALL INSTRUCTIONS)

#### AVOIDING THE RISK TO CHILDREN

##### DANGER - RISK OF CHILD DROWNING

Extreme caution must be exercised to prevent unauthorized access by children. To avoid accidents, ensure that children cannot use a spa unless they are supervised at all times.

##### WARNING

To reduce the risk of injury, do not permit children to use this spa unless they are closely supervised at all times.

- To reduce the risk of injury, lower water temperatures are recommended for young children. Children are especially sensitive to hot water.
- Extreme caution must be exercised to prevent unauthorized access by children. To avoid accidents, ensure that children cannot use a spa unless they are supervised at all times.

##### DO:

- Make sure you always lock the child resistant locks after using the spa for your children's safety. Every **Hot Spring** spa is equipped with a locking cover that meets the ASTM F1346-91 Standard for Safety Covers.
- Test the water temperature with your hand before allowing children to enter the spa to be sure that it's comfortable. Children are especially sensitive to hot water.
- Remind children that wet surfaces can be very slippery. Make sure that children are careful when entering or exiting the spa.

##### DON'T:

- Allow children to climb onto the spa cover.
- Allow children to have unsupervised access to the spa.

#### AVOIDING THE RISK OF ELECTROCUTION

##### DANGER - RISK OF ELECTROCUTION

- Connect only to a grounded source.
- Do not bury the power cord. A buried power cord may result in death, or serious personal injury due to electrocution if direct burial-type cable is not used, or if improper digging occurs.
- A ground terminal (pressure wire connector) is provided on the control box inside the unit to permit connection of a minimum No. 8 AWG solid copper bonding conductor between this point and any metal equipment, metal water pipe, metal enclosures of electrical equipment, or conduit within 5 feet (1.5 m) of the unit as needed to comply with local requirements.
- Do not operate the audio main controls while inside the spa (if spa is equipped with an audio component).

- Do not connect any auxiliary components (for example, cable additional speakers, headphones, additional audio components) to the audio system unless approved by **WATKINS WELLNESS**.
- Do not self service audio component by opening spa door as this may expose dangerous voltage or other risk of injury. Refer all servicing to qualified service personnel.
- Do not attach an external antennae to a spa audio system unless installed by a licensed electrician in accordance with Article 810 of the National Electric Code, ANSI/NFPA 70.

##### WARNING

- To reduce the risk of electrical shock, replace a damaged cord immediately. Failure to do so may result in death or serious personal injury due to electrocution.
  - Your spa is provided with a Ground Fault Circuit Interrupter (GFCI) for user and equipment protection. To ensure proper operation of this important safety device, test according to the following instructions per electrical configuration.
  - **Cord-Connected 115 volt, 15 or 20 amp models:** The GFCI is located at the end of the power cord. Before each use, with the unit operating, push the TEST button. The unit should stop operating and the GFCI power indicator will go out. Wait 30 seconds and then reset the GFCI by pushing the RESET button. The GFCI power indicator will turn on, restoring power to the spa. If the interrupter does not perform in this manner, there may be an electrical malfunction and with it, the possibility of an electric shock. Disconnect the power until the problem has been corrected.
  - **230 volt permanently installed or converted models:**
    - A ground terminal is provided on the terminal block (TB-1, system ground terminal) located inside the control box. To reduce the risk of electric shock, connect this terminal to the grounding terminal of your electrical service or supply panel with a continuous green, insulated copper wire. The wire must be equivalent in size to the circuit conductors supplying the equipment. In addition, a bonding terminal (pressure wire connector) is provided on the outside of the control box for bonding to local ground points. To reduce the risk of electric shock, this connector should be bonded with a No. 8 AWG solid copper wire to any metal ladders, water pipes, or other metal within 5 feet (1.5 m) of the spa to comply with local requirements. The means of disconnection must be readily accessible, but must be installed at least 5 feet (1.5 m) from the spa.
    - Your spa is provided with a suitably rated circuit breaker to open all ungrounded supply conductors.
    - Your spa uses ground fault circuit interrupters in the electrical subpanel. Before each use of the spa and with the unit operating, push the TEST button on each breaker. The switch should click over to the "Trip" position. Wait 30 seconds and reset each GFCI breaker by switching it completely off and then completely on. The switch should then stay on. If either of the interrupters does not perform in this manner, it is an indication of an electrical malfunction and the possibility of an electric shock. Disconnect the power until the fault has been identified and corrected.
- IMPORTANT:** Failure to wait 30 seconds before resetting the GFCI may cause the spa's Power Indicator (on the control panel) to blink. If this occurs, repeat the GFCI test procedure.

## DANGER - RISK OF ELECTRICAL SHOCK

- Install at least 5 feet (1.5 m) from all metal surfaces. A spa may be installed within 5 feet (1.5 m) of a metal surface if each metal surface is permanently connected by a minimum No. 8 AWG solid copper conductor attached to the wire ground connector on the terminal box that is provided for this purpose if in accordance with National Electrical Code ANSI/NMFA70-1993.
- Do not permit any electrical appliances, such as a light, telephone, radio, or television within 5 feet (1.5 m) of a spa. Failure to maintain a safe distance may result in death, or serious personal injury due to electrocution, if the appliance should fall into the spa.
- Install your spa in such a way that drainage is away from the electrical compartment and from all electrical components.

### DO:

- Be sure your spa is connected to the power supply correctly - use a licensed electrical contractor.
- Disconnect the spa from the power supply before draining the spa or servicing the electrical components.
- Test the Ground Fault Circuit Interrupter before each use.
- Replace audio components only with identical components (if your spa is equipped with an audio component).

### DON'T:

- Use the spa with the equipment compartment door removed.
- Place electrical appliances within 5 feet (1.5m) of the spa.
- Use an extension cord to connect the spa to its power source. The cord may not be properly grounded and the connection is a shock hazard. An extension cord may cause a voltage drop, which will cause overheating of the jet pump motor and motor damage.
- Attempt to open the electrical control box. There are no user serviceable parts inside.

## RISKS TO AVOID

### DANGER - RISK OF INJURY

- To reduce the risk of injury to persons, DO NOT remove suction fittings (filter standpipes) located in the filter compartment.
- The suction fittings in the spa are sized to match the specific water flow created by the pump. Never replace a suction fitting with one rated less than the flow rate marked on the original suction fitting.
- There is a danger of slipping and falling. Remember that wet surfaces can be very slippery. Take care when entering or exiting the spa.
- Never operate spa if the suction fittings are broken or missing.
- People with infectious diseases should not use the spa.
- Keep any loose articles of clothing, long hair, or hanging jewelry away from rotating jets or other moving components.

## INCREASED SIDE EFFECTS OF MEDICATION

- The use of drugs, alcohol may cause unconsciousness with the possibility of drowning.
- Persons using medications should consult a physician before using a spa; some medication may cause a user to become drowsy, while other medication may affect heart rate, blood pressure, and circulation.

- Persons taking medications which induce drowsiness, such as tranquilizers, antihistamines, or anticoagulants should not use the spa.

## HEALTH PROBLEMS AFFECTED BY SPA USE

- Pregnant women should consult a physician before using spa.
- Persons suffering from obesity, or with a medical history of heart disease, low or high blood pressure, circulatory system problems, or diabetes should consult a physician before using spa.

## UNCLEAN WATER

- Keep the water clean and sanitized with correct chemical care. Maintain the recommended levels for your **HOT SPRING** spa.
- Refer to Water Quality and Maintenance section in the Owner's Manual for complete instructions.

**IMPORTANT:** Turn on the jet pump for a least ten minutes after adding ANY spa water chemicals into the filter compartment.

Clean the filter cartridges monthly to remove debris and mineral buildup which may affect the performance of the hydromassage jets, limit the flow, or trip the high limit thermostat, which will turn off the entire spa.

## AVOIDING THE RISK OF HYPERTHERMIA

Prolonged immersion in hot water can result in HYPERTHERMIA, a dangerous condition which occurs when the internal temperature of the body reaches a level above normal 98.6°F (37°C). The symptoms of hyperthermia include unawareness of impending hazard, failure to perceive heat, failure to recognize the need to exit the spa, physical inability to exit the spa, fetal damage in pregnant women, and unconsciousness resulting in a danger of drowning.

### WARNING

The use of alcohol, drugs, or medication can greatly increase the risk of fatal hyperthermia in hot tubs and spas.

## TO REDUCE THE RISK OF INJURY

- The water in the spa should never exceed 104°F (40°C). Water temperatures between 100°F and 104°F (36°C and 40°C) are considered safe for a healthy adult. Lower water temperatures are recommended for extended use (exceeding ten minutes) and for young children. Extended use can cause hyperthermia.
- Pregnant or possibly pregnant women should limit spa water temperatures to 100°F (36°C). Failure to do so may result in permanent injury to your baby.
- Do not use spa immediately following strenuous exercise.

## AVOIDING THE RISK OF SKIN BURNS

- To reduce the risk of injury, before entering a spa the user should measure the water temperature with an accurate thermometer.
- Test the water with your hand before entering the spa to be sure it's comfortable.

## SAFETY SIGN

Each **HOT SPRING** spa is shipped with a SAFETY SIGN in the owner's package. The sign, which is required as a condition of Product Listing, should be permanently installed where it is visible to the users of the spa. To obtain additional SAFETY SIGNS, contact your **HOT SPRING** dealer and request Part #70798.

# IMPORTANT SPA INSTRUCTIONS

The following contains important spa information, and we strongly encourage you to read and apply them.

### DO:

- Use and lock the vinyl cover when the spa is not in use, whether it is empty or full.
- Follow the Spa Care and Maintenance recommendations stated in this manual.
- Use only approved accessories and recommended spa chemicals and cleaners.

### DON'T

- Leave the **HOT SPRING** spa exposed to the sun without water or the cover in place. Exposure to direct sunlight can cause solar distress of the shell material.
- Roll or slide the spa on its side. This will damage the siding.
- Lift or drag the vinyl cover by using the cover lock straps; always lift or carry the cover by using the handles.
- Attempt to open the electrical control box. There are no user serviceable parts inside. Opening of the control box by the spa owner will void the warranty. If you have an operational problem, carefully go through the steps outlined in the Troubleshooting section. If you are not able to resolve the problem, contact your authorized **HOT SPRING** dealer. Many problems can easily be diagnosed over the telephone by an Authorized Service Technician.

## SPA SHELL

Your **HOT SPRING** spa has an acrylic shell. Stains and dirt generally will not adhere to your spa's surface. A soft rag should easily remove most dirt. Most household chemicals are harmful to your spa's shell (see below for detailed information on cleaning agents). Always rinse off any spa shell cleaning agent with fresh water.

### IMPORTANT:

1. The following products are the **ONLY** approved cleaning agents for your **HOT SPRING** spa shell: plain water, **HOT SPRING FRESHWATER** Spa Shine, or Soft Scrub®. The use of alcohol or any other household cleaner other than those listed to clean the spa shell surface is **NOT** recommended. **DO NOT** use any cleaning products containing abrasives or solvents since they may damage the shell surface, specifically: Simple Green®, Windex® or Spa Mitt. **NEVER USE HARSH CHEMICALS!** Damage to the shell by use of harsh chemicals is not covered under the warranty. Always rinse off any spa shell cleaning agent with fresh water.
2. Iron and copper in the water can stain the spa shell if allowed to go unchecked. Ask your **HOT SPRING** dealer about a Stain and Scale Inhibitor to use if your spa has a high concentration of dissolved minerals. Watkins recommends **FRESHWATER** Stain & Scale Defense.
3. Keep all cleaners out of the reach of children and use care when applying.

# SAVE THESE INSTRUCTIONS

## HIGHLIFE / LIMELIGHT

### ELECTRICAL REQUIREMENTS

**IMPORTANT:** Fill the spa with water before turning on the power.

Your **HOT SPRING** spa has been carefully designed to give you maximum safety against electrical shock. Connecting the spa to an improperly wired circuit will negate many of the spa's safety features. Improper wiring may also cause electrocution, risk of fire, and other risks of injuries. Please read and follow the electrical installation requirements and instructions for your specific spa model completely!

### 230 VOLT PERMANENTLY CONNECTED

**HOT SPRING** spas must be wired in accordance with all applicable local electrical codes. All electrical work should be done by an experienced, licensed electrician. We recommend the use of appropriate electrical conduit, fittings, and wire for all circuits.

The following diagram illustrates how to wire 230 volt permanently connected spa models:

- An electrical subpanel containing two GFCI breakers is included with each 230 volt spa. We recommend that this subpanel be used to supply power to the spa.

- The subpanel requires a 50 amp, single phase, 230 volt, four wire service (two line, one neutral, one ground). The grounding conductor must not be less than #10 AWG. Refer to local codes and to NEC 250-122 table.
- Mount the subpanel in the vicinity of the spa, but not closer than five feet away, in accordance with all local codes. (N.E.C. 680-38 to 41-A-3)

Once your spa has been filled with water, turn it on and test all of the circuit breakers.

**IMPORTANT:** If both breakers immediately trip, verify that the wires are correctly connected. Each breaker should be tested prior to each use. Here's how:

- Push the "TEST" button on each GFCI breaker, and observe it click OFF.
- Wait 30 seconds, then push the breaker switch to the OFF (down) position (to ensure that it has completely disengaged), then push the breaker switch to the ON (up) position. If you don't wait 30 seconds, the spa's power indicator may continue to blink – try again.

If any of the GFCI breakers fails to operate in this manner, your spa may have an electrical malfunction, and you may be at risk of electrical shock. Turn off all circuits and do not use the spa until the problem has been corrected by an authorized service agent.

**⚠️ WARNING:** Removing, or bypassing any GFCI breaker will result in an unsafe spa and will void the spa's warranty.

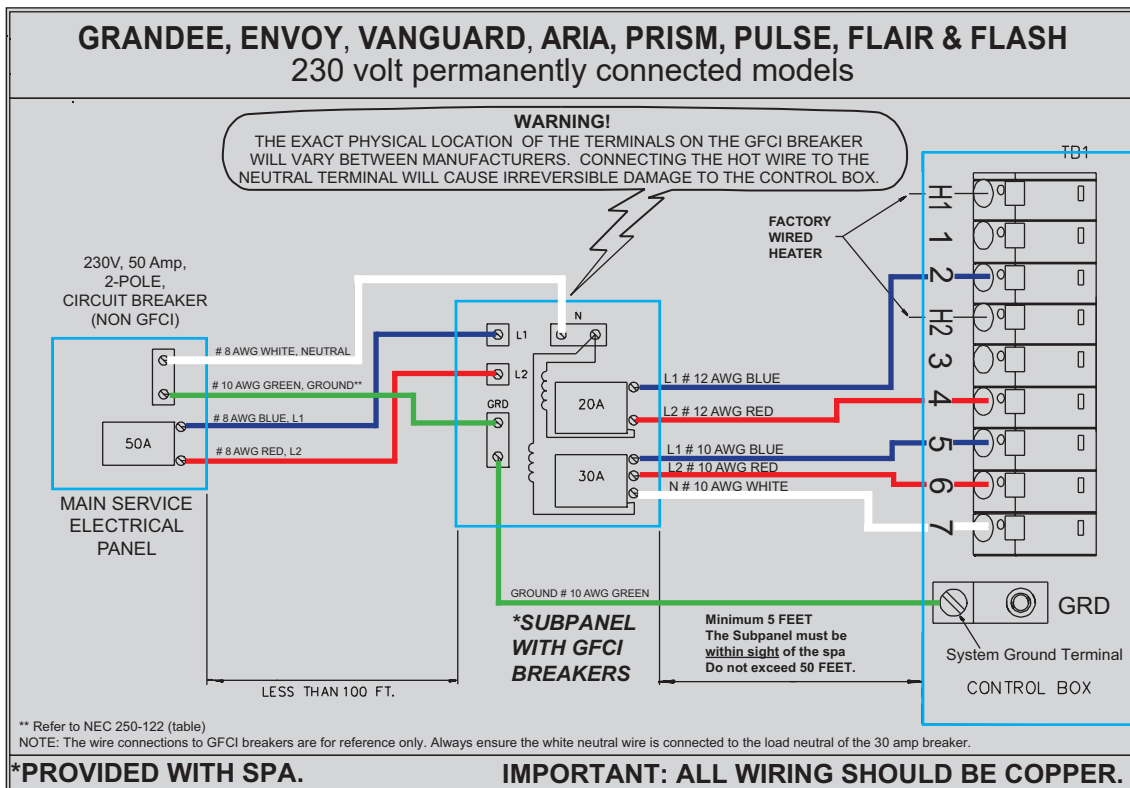



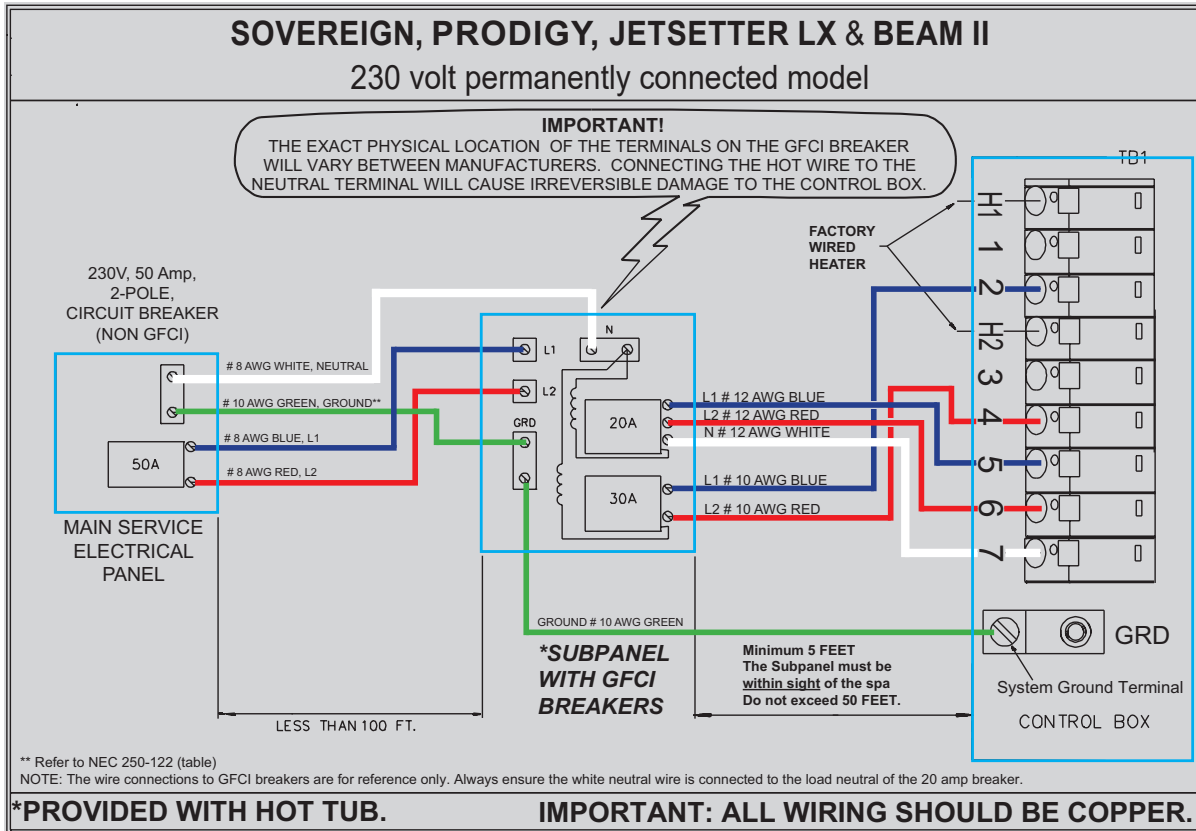

## 230 VOLT CONVERTED PRISM

The **PRISM** will run with a 50 service but requires an additional 20 amp breaker in order to operate the heater and jet pump 3 at the same time. Without the additional 20 amp breaker, the heater will NOT operate while the jets are used with jet pump 3 on.

This subpanel requires a 70 amp, single phase, 230 volt, four wire service (two line, one neutral, one ground). The ground wire must never be less than #10 AWG. Use NEC 250-122 (table) and local codes for more information. A minimum #6 AWG solid copper bond wire is also required.

Mount the subpanel in the vicinity of the spa, but not within five feet, in accordance with local codes.

**HOT SPRING SPAS MUST BE WIRED IN ACCORDANCE WITH ALL APPLICABLE LOCAL ELECTRICAL CODES. ALL ELECTRICAL WORK SHOULD BE DONE BY AN EXPERIENCED LICENSED ELECTRICIAN. WE RECOMMEND THE USE OF APPROPRIATE ELECTRICAL CONDUIT, FITTINGS, AND WIRE FOR ALL CIRCUITS.**

**IMPORTANT:** Service Technician must reconfigure spa using the soft jumpers to allow spa heater to run concurrent with jet pump.

**NOTE:** Long wiring runs may require larger-gauge wire than stated.

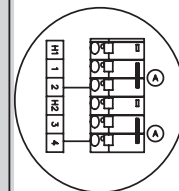
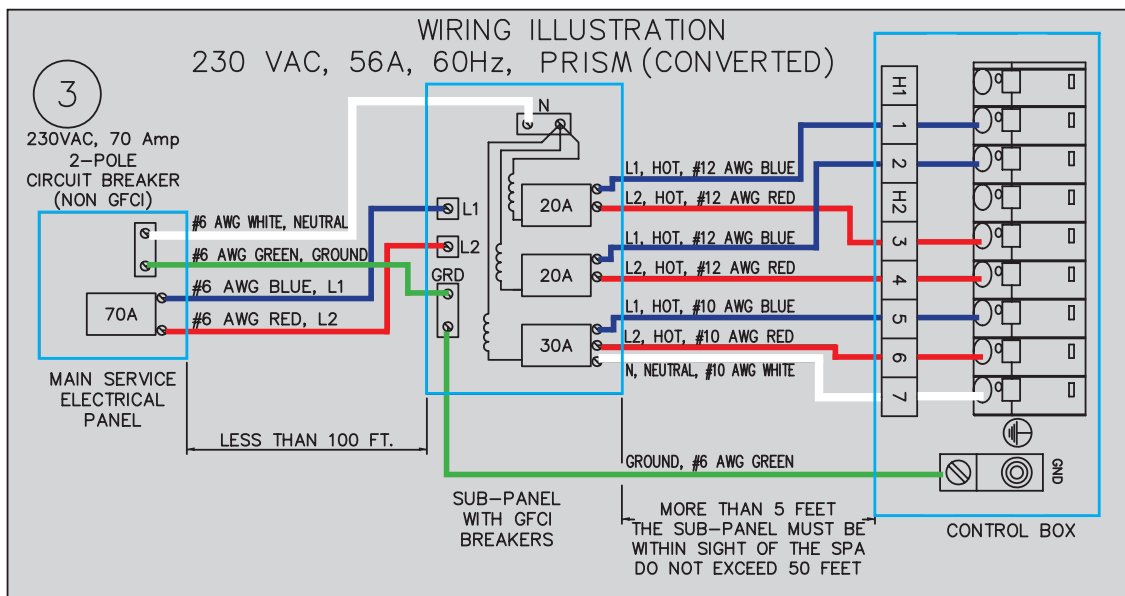

**Remove power jumpers A from TB-1**



# ELECTRICAL INFORMATION

## 115 VOLT JETSETTER & BEAM I MODELS

The Ground Fault Circuit Interrupter (GFCI) is a safety device that is designed to detect as little as 5 milliamps ( $\pm 1\text{mA}$ ) of electrical current leakage to ground. **WATKINS WELLNESS** recommends that the GFCI be tested prior to each use to ensure it is functioning correctly. With the spa connected to the power supply, push the "Test" button. The spa should stop operating and the GFCI power indicator will go out. Wait 30 seconds and then reset the GFCI by pushing the Reset button. The GFCI power indicator will turn on, restoring power to the spa. If the interrupter does not perform in this manner, it is an indication of an electrical malfunction and the possibility of an electric shock. Disconnect the plug from the receptacle until the fault has been identified and corrected.

**IMPORTANT:** Failure to wait 30 seconds before resetting the GFCI may cause the spa's Power indicator (on the control panel) to blink. If this occurs, repeat the GFCI test procedure.

Never use the GFCI as a means to disconnect power to the spa (always unplug it). If the GFCI is tripped while the spa is plugged in, and a power outage occurs, when power returns the GFCI will automatically reset and power will flow to the spa.

## 115 VOLT OPERATION (60Hz ONLY)

The spa must be connected to a dedicated 115 volt, 20 amp, GFCI protected, grounded circuit. The term "dedicated" means the electrical circuit is not being used or shared for any other electrical items (patio lights, appliances, garage circuits, etc.). If the spa is connected to a non-dedicated circuit, overloading will result in "nuisance tripping" at the main panel. This requires frequent resetting of the breaker switch at the house electrical breaker panel and introduces the possibility of damage or failure of spa equipment. The dedicated circuit must be properly wired; that is, it must have a 20-amp GFCI circuit breaker in the house breaker panel, #12 AWG or larger wire (including the ground wire) and the correct polarity throughout the circuit.

## NEVER CONNECT THE SPA TO AN EXTENSION CORD!

A pressure wire connector is provided on the exterior surface of the control box, inside the spa. This is to permit the connection of a ground bonding wire between this point and any metal equipment, enclosures, reinforced concrete pad, pipe, or conduit within 5 feet of the spa (if needed to comply with local building code requirements). The bonding wire must be at least a #10-AWG solid copper wire. Bond the spa to all exposed metal equipment or fixtures, handrails, and concrete pad per N.E.C. Article 680 and all local codes.

MINIMUM DISTANCE AFTER SPA INSTALLATION: 5'

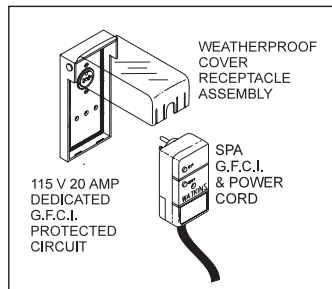
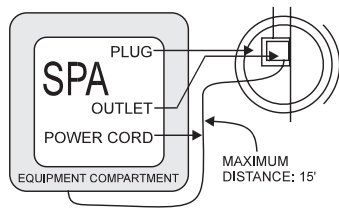

## INSTALLATION INSTRUCTIONS

All 115 volt models come equipped with approximately 15 feet of useable power cord (this is the maximum length allowed by Underwriters Laboratory and the National Electric Code). When the spa is installed, the power cord will come out of the bottom of the equipment compartment door. For your safety, when the electrician is installing the 20 amp single electrical outlet and waterproof cover, the outlet should be no closer than 5 feet (1.5 meters) and no farther than 10 feet from the spa [reference National Electrical Code 680-6a(1) and 680-41a].

The Ground Fault Circuit Interrupter (GFCI) is located at the end of the power cord. This device is for your protection. It is very important to protect it from rain and other moisture. Test once a month, with the plug connected to the power supply,

1. Push the "TEST" button on the GFCI breaker. The spa should stop operating and the GFCI power indicator will go out.
2. Wait 30 seconds, then push the "RESET" button. Power will be restored to the spa and the GFCI power indicator will turn on.

If the GFCI fails to operate in this manner, your spa may have an electrical malfunction, and you may be risking electrical shock. Turn off all circuits and do not use the spa until the problem has been corrected by an authorized service agent.

**⚠ WARNING:** Removal of the GFCI from the spa's power cord will result in an unsafe spa and will void the spa's warranty.

**IMPORTANT:** Should you ever find the need to move or relocate your **HOT SPRING** spa, it is essential that you understand and apply these installation requirements. Your **HOT SPRING** spa has been carefully engineered to provide maximum safety against electric shock. Remember, connecting the spa to an improperly wired circuit will negate many of its safety features.

## ADVANTAGE TO HAVING YOUR SPA CONVERTED

- In the 115 volt configuration, either the heater, or the jet pump can operate, but they can't work at the same time. In a 115 volt system, as long as the jet pump is activated, the heater will not turn on. On the other hand, when the spa is converted to operate in the 230 volt configuration, the heater and jet pump can operate simultaneously.
- The heater will operate at 1500 watts when the spa is configured as a 115 volt cord-and-plug connected model, and at 6000 watts when the spa is configured as a 230 volt converted model heating your spa water faster.

## 115/230 VOLT CONVERTIBLE MODEL

The 115 volt models can be converted to 230 volt operation with the addition of a subpanel and a control box wiring change. Consult your dealer before attempting to convert from 115 volt operation to 230 volt operation. Any damage to the spa from improper conversion is not covered under the warranty.

## 230 VOLT CONVERTED MODELS

**HOT SPRING** spas must be wired in accordance with all applicable local electrical codes. All electrical work should be done by an experienced, licensed electrician. We recommend the use of appropriate electrical conduit, fittings, and wire for all circuits.

Refer to the following instructions to convert from 115 volt to 230 volt

**IMPORTANT:** Converting the spa to 230 volt operation will require both an authorized **HOT SPRING** service agent and a qualified electrician.

Required Part: A Subpanel (230 volt Convertable) available from your **HOT SPRING** dealer.

1. Disconnect the power cord from the house receptacle.
2. Open the equipment compartment door.
3. Remove the screws on the front of the spa control box.
4. Open the control box cover.
5. Identify Terminal block located in the lower left-hand corner inside the control box.
6. Refer to illustration, Step 1. Remove the 2 pin jumper attached to terminals 4 and 5.
7. Refer to illustration, Step 1. Remove the wire jumper from terminals 2, and 6.
8. Refer to illustration, Step 2. Remove the power cord wires from 5, 7 and GRD (not illustrated).
9. Unscrew the power cord strain relief and remove the power cord from the access hole in the control box.

**⚠ WARNING:** Do not allow pliers to contact any electronic components inside the control box.

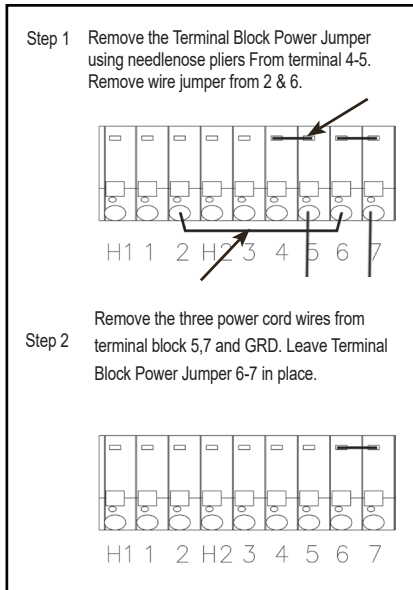

Converting from 115 volts to 230 volts changes the voltage supplied to the heater from 115-volts to 230 volts. The jet pump will continue to operate at 115 volts.

Have your licensed electrician wire subpanel from a 50A Main Service, then from subpanel into the spa's control box using the following illustration or use the wire diagram on the inside of the control box lid.

**IMPORTANT:** The subpanel must be placed in sight of the spa, at a minimum distance of 5 feet away.

## WIRING CONNECTIONS

**IMPORTANT:** Fill the spa with water before turning on the power

- Once your spa has been filled with water, turn it on and test all the circuit breakers.

Each breaker should be tested prior to each use. Here's how:

1. Push the "TEST" button on each GFCI breaker, and observe it click off.
2. Wait 30 seconds, then push the breaker switch to the OFF (down) position (to ensure that it has completely disengaged), then push the breaker switch to the ON (up) position. If you don't wait 30 seconds, the spa's power indicator may continue to blink – try again.

If any of the GFCI breakers fails to operate in this manner, your spa may have an electrical malfunction, and you may be risking electrical shock. Turn off all circuits and do not use the spa until the problem has been corrected by an authorized service agent.

**IMPORTANT:** Service Technician must reconfigure spa using the soft jumpers to allow spa heater to run concurrent with jet pump.

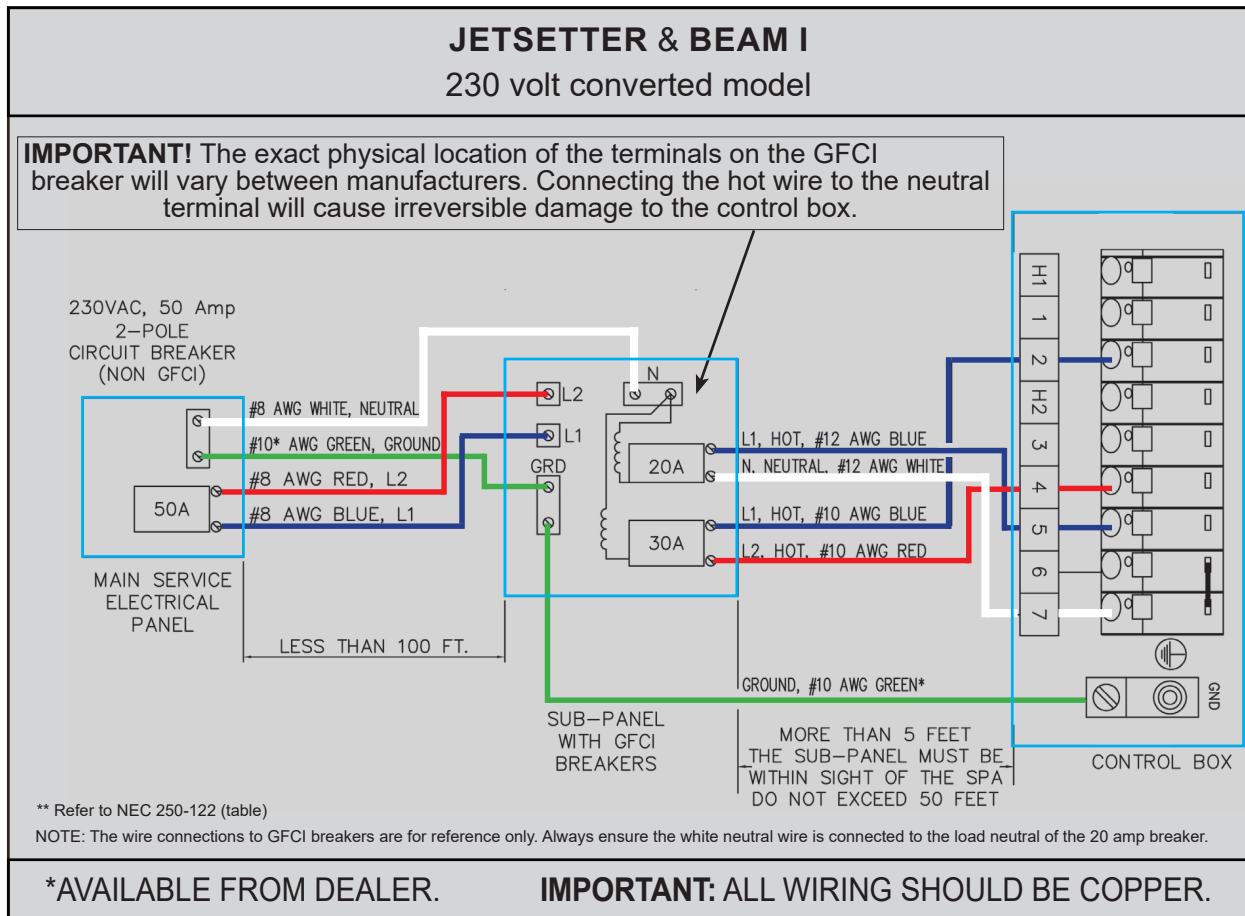

# HIGHLIFE® COLLECTION

## LIMITED WARRANTY

EN

FR

ES

Watkins Manufacturing Corporation ("Watkins") warrants from the date of installation to the original consumer purchaser ("you") the following when your Hot Spring® Highlife® Collection spa is purchased from an authorized dealer/service provider ("dealer").

**7 Year Shell Surface Warranty**  
Watkins warrants the acrylic surface material of your Hot Spring Highlife Collection spa to not leak and be free from defects in materials and workmanship for seven years.

**5 Year No Leak Plumbing Warranty**  
Watkins warrants your Hot Spring Highlife Collection spa against leaks caused by defects in materials and workmanship for five years. This warranty specifically covers leaks from the wall fittings, jet fittings, internal plumbing, internal glue joints, drains, hoses, and all bonded parts.

**5 Year Component Warranty**  
Watkins warrants the electrical components, pumps, jets (including the Moto-Massage® jets), air valves, levers, bezels and other Hot Spring spa components against defects in materials and workmanship for five years. Some parts, most of which can be changed out without the use of tools, such as filter cartridges, filter lid, spa pillows and cover locks, are not included in this warranty, but are warranted to be free from defects in materials and workmanship at the time of delivery to you. Spa covers and other spa accessories are specifically excluded from this warranty, although they may be covered by other warranties. Please check with your Hot Spring spa dealer for details.

**5 Year No-Fault® Heater Warranty**  
Watkins warrants the No-Fault heater to be free from defects in materials and workmanship for five years. This warranty does not cover commercial or industrial use spas or spas that have been improperly installed.

**5 Year Cabinet Warranty**  
Watkins warrants your Hot Spring Highlife Collection spa's cabinet to be free from defects in materials and workmanship for five years. This warranty specifically covers the cabinet's structural integrity, including assembly. This warranty does not cover the surface stain of the spa.

The cosmetic finish of the cabinet is warranted to be free from defects in materials and workmanship at the time of delivery to you. Fading and weathering of the surface may naturally occur over time and are not considered defects. Refer to your Hot Spring Highlife Collection spa Owner's Manual for proper care and maintenance instructions.

**2 Year Light Assembly Warranty**  
Watkins warrants the factory-installed light assembly, which includes underwater and bar top lighting, to be free from defects in materials and workmanship for two years.

**1 Year Wireless Remote-Control Battery Warranty**  
Watkins warrants the battery in the wireless remote-control against defects in materials and workmanship for one year. For battery replacement, directions refer to your Hot Spring Highlife Collection spa Owner's Manual.

The following applies to all of the warranties listed:

### Extent of Warranty

This warranty extends only to the original consumer purchaser of the Hot Spring Highlife Collection spa when purchased and originally installed within the country of purchase. This warranty begins on the date of installation of the spa, but in no event later than one year from the date of purchase. This warranty terminates upon any transfer of ownership of the spa, or if the spa is installed or relocated outside the country of purchase prior to the expiration of the warranty period.

### Warranty Performance

To make a claim under this warranty, contact the dealer where you purchased your spa. In the event you are unable to obtain service from your dealer, please write Watkins at 1280 Park Center Drive, Vista, California, 92081, Attn: Customer Service Department or call (800) 999-4688 or via e-mail, [customerservice@watkinsmfg.com](mailto:customerservice@watkinsmfg.com). You must give Watkins, and/or your dealer written notice of any warranty claim, along with a copy of your original purchase receipt indicating the date of the purchase, within thirty (30) days of the time you discover the claim. Watkins reserves the right to inspect the malfunction or defect on location.

Watkins or its Authorized Service Agent will repair any defects covered by this warranty. Except as described herein, you will not be charged for parts and/or labor necessary to repair the spa for defects covered by this warranty. In some cases, the servicing dealer may charge you a repairperson travel/service charge that is not covered by this warranty. Please contact your dealer for information regarding any such charges.

### Limitations

Except as described above, this warranty does not cover defects or damage due to normal wear and tear, improper installation, alteration without Watkins prior written consent, accident, acts of God, misuse, abuse, commercial or industrial use, use of an accessory not approved by Watkins, failure to follow Watkins Pre-Delivery Instructions or your spa's Owner's Manual, or repairs/installations made or attempted by anyone other than an authorized representative of Watkins. Alteration includes, but is not limited to, any component or plumbing change, or electrical conversion. Visit [www.hotspring.com](http://www.hotspring.com) or contact your dealer for a list of manufacturer approved accessories.

### Disclaimers

**ANY IMPLIED WARRANTIES, INCLUDING THE IMPLIED WARRANTIES OF MERCHANTABILITY AND FITNESS FOR A PARTICULAR PURPOSE, ARE LIMITED TO THE STATUTORY PERIOD OR THE DURATION OF THE APPLICABLE WARRANTY STATED ABOVE, WHICHEVER IS SHORTER.** Some states and countries (including Quebec) do not allow limitations on how long an implied warranty may last, so the above limitations may not apply to you. Notice to residents of the State of New Jersey: The provisions of this warranty, including its limitations, are intended to apply to the fullest extent permitted by the laws of the State of New Jersey.

**TO THE MAXIMUM EXTENT PERMITTED BY APPLICABLE LAW, THIS WARRANTY DOES NOT COVER INCIDENTAL OR CONSEQUENTIAL DAMAGES, INCLUDING BUT NOT LIMITED TO THE REMOVAL OF ANY DECK OR CUSTOM FIXTURE OR ANY COST TO REMOVE OR REINSTALL THE SPA, IF NEEDED.** Some states and countries (including Quebec) do not allow the exclusion or limitation of incidental or consequential damages, so the above limitations may not apply to you.

### Legal Remedies

This warranty gives you specific legal rights, and you may have other rights which vary from state to state, province to province or country to country. This warranty is not transferable.



**HotSpring®**

*Every day made better®*